

# NQZ

## Pneumatic actuator with integrated digital measuring system

Pneumatic actuators with digital measuring system are particularly suitable for:

- Detection of stopping position.
- Anti-collision control in critical sequencing cycles.
- Level control in palletization / de-palletization of stacked objects.
- Identification, classification and dimensional selection of objects (tolerances and rejects).
- Certification stations of machined pieces or tool breaking on machines for chip removal.



### TECHNICAL CHARACTERISTICS

|                            |                                       |    |    |      |    |
|----------------------------|---------------------------------------|----|----|------|----|
| Ambient temperature        | -10 to 70°C                           |    |    |      |    |
| Fluid                      | 30 µm filtered air                    |    |    |      |    |
| Working pressure           | 2 to 10 bar                           |    |    |      |    |
| Thread of the screw        | Ø                                     | 32 | 40 | 50   | 63 |
|                            | mm/turn                               | 12 | 16 | 20,5 |    |
| Max speed                  | 0,2 m/s (detector) 0,8 m/s (actuator) |    |    |      |    |
| Precision of repeatability | ± 0.02 mm                             |    |    |      |    |
| Bores                      | Ø 32 - 40 - 50 - 63 mm                |    |    |      |    |
| Cushioning                 | adjustable pneumatic on both sides    |    |    |      |    |

### CONSTRUCTIVE CHARACTERISTICS

|                           |                                    |
|---------------------------|------------------------------------|
| End caps                  | die-cast aluminium alloy           |
| Barrel                    | extruded barrel in aluminium alloy |
| Piston                    | aluminium                          |
| Guide slide               | acetalic resin                     |
| Piston rod                | chromium-plated steel              |
| Piston seal               | double-lip seal in nitrile rubber  |
| Guide bush for piston rod | acetalic resin                     |
| Shock absorber seals      | nitrile rubber                     |
| Magnet                    | ferrite rubber (standard)          |

### ELECTRIC CHARACTERISTICS

|                             |                                |
|-----------------------------|--------------------------------|
| Voltage                     | 5 to 24 V DC                   |
| Output                      | level L < 0,5 V - level H V CC |
| Limit frequency             | 60 KHz                         |
| Impedance                   | 2 Kohm                         |
| Power consumption           | 40 mA max                      |
| Time of upstroke/downstroke | <1 µS                          |
| Pulse rate                  | 500                            |
| Resolution                  | ± 0,01 pulses/turn             |

### CODIFICATION KEY

|   |   |   |   |   |   |   |   |   |   |
|---|---|---|---|---|---|---|---|---|---|
| N | Q | Z | 0 | 3 | 2 | 0 | 3 | 5 | 0 |
| 1 |   | 2 |   |   | 3 |   |   |   |   |

| 1 Series   | 2 Bore (mm)                                      | 3 Maxstroke (mm)                                 |
|--|--|--|
| NQZ = Pneumatic actuator with integrated digital measuring system<br>Ø 32 to 63 mm | 032 = Ø32<br>040 = Ø40<br>050 = Ø50<br>063 = Ø63 | 350 (Ø32)<br>450 (Ø40)<br>600 (Ø50)<br>750 (Ø63) |

When the detector is used in environments with electromagnetic disturbances exceeding those allowed by the EN50081-2 standard, also request the adapter TAE011A10305 (our production) or use suppressors of electromagnetic interferences available on the market.

Scheme of encoder

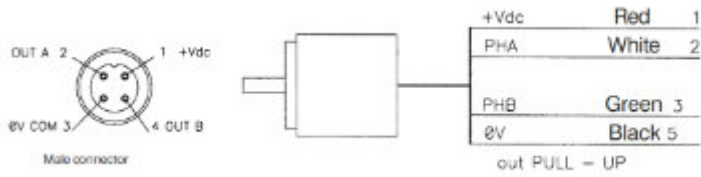

The pneumatic cylinders with digital measuring of the position derive from the respective fluidic axes with numerical control and are particularly suitable for:

- **Detection of stopping position**
- **Anti-collision control for cycles with critical sequence**
- **Level control relating to the palletization and/or de-palletization of objects placed one onto the other**
- **Identification, classification and dimensional choice of objects (tolerances and rejects)**
- **Certification stations of machined pieces or breaking of tools on machines due to chip removal.**

The device can be used in two different ways:

- **As digital measuring detector**
- **As pneumatic actuator with digital detection of the position**

In the first case the system does not need to be connected to the moving part of the mechanism as it generates by itself the movement by means of an internal pusher with bidirectional pneumatic function at low pressure. This pusher, operated by a 5-way microvalve, moves autonomously until it meets the obstacle and measures the position by means of the encoder whose indication may be visualised on a digital display with centesimal resolution. The precision repeatability is  $\pm 0,02$  mm.

The speed of the impact against the obstacle is limited by appropriate calibrated reducers which are built into the detector, whilst it is possible to adequately regulate the translation speed by means of a normal pressure regulator.

In order to guarantee a reading with the indicated repeatability, the translation speed must be as constant as possible.

In the second case the air supply of the device is effected by means of the network pressure adequately regulated according to the necessity; it depends on the load to be moved or is prearranged to exert the desired thrust once reaching the object to be detected.

NQZ Ø 32 to 63 mm

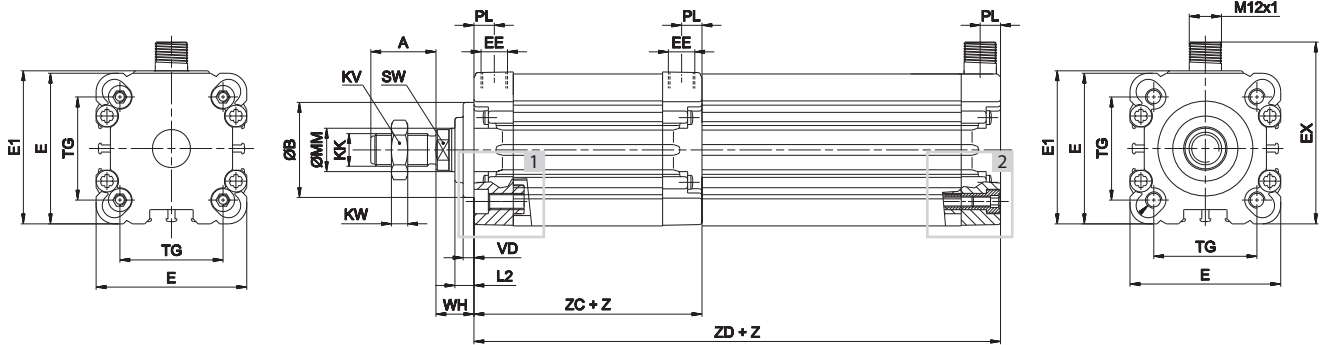
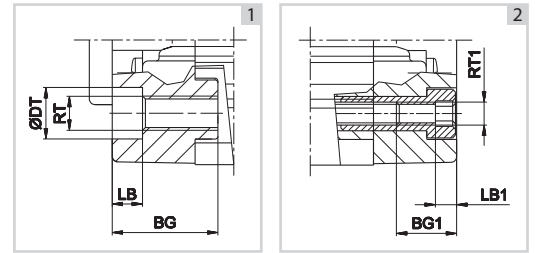

Z = Stroke

| Ø  | A  | B  | BG | BG1 | DT | E  | EE   | EX | E1 | KK       | KV | KW |
|----|----|----|----|-----|----|----|------|----|----|----------|----|----|
| 32 | 22 | 30 | 18 | 6,5 | 9  | 46 | G1/8 | 57 | 47 | M10x1,25 | 17 | 6  |
| 40 | 24 | 35 | 18 | 6,5 | 9  | 56 | G1/8 | 67 | 57 | M12x1,25 | 19 | 7  |
| 50 | 32 | 40 | 24 | 6,5 | 11 | 66 | G1/8 | 77 | 67 | M16x1,5  | 24 | 8  |
| 63 | 32 | 45 | 24 | 6,5 | 11 | 79 | G1/8 | 90 | 80 | M16x1,5  | 24 | 8  |

| Ø  | LB  | LB1 | L2 | MM | PL  | RT | RT1 | SW | TG   | VD | WH | ZC  | ZD  |
|----|-----|-----|----|----|-----|----|-----|----|------|----|----|-----|-----|
| 32 | 5,3 | 3,5 | 7  | 12 | 7,5 | M6 | M4  | 10 | 32,5 | 4  | 14 | 84  | 186 |
| 40 | 5,3 | 3,5 | 7  | 16 | 7,5 | M6 | M6  | 13 | 38   | 4  | 14 | 89  | 194 |
| 50 | 6,5 | 3,5 | 10 | 20 | 7,5 | M8 | M6  | 17 | 46,5 | 5  | 18 | 94  | 204 |
| 63 | 6,5 | 3,5 | 10 | 20 | 7,5 | M8 | M6  | 17 | 56,5 | 5  | 18 | 114 | 223 |

- For magnetic sensor use DF series
- Fixing elements and accessories: same as for STRONG series cylinders